



SGM7SZ126

Small Logic Buffer with Three-State Output

GENERAL DESCRIPTION

The SGM7SZ126 is a single buffer with three-state output from SGMICRO's Small Logic series. The device is fabricated with advanced CMOS technology to achieve ultra-high speed with high output drive while maintaining low static power dissipation over a broad V_{CC} operating range. The device is specified to operate over the 1.65V to 5.5V V_{CC} operating range. The inputs and output are high impedance when V_{CC} is 0V. Inputs tolerate voltages up to 6V, independent of V_{CC} operating voltage. The output tolerates voltages above V_{CC} in the 3-state condition.

The SGM7SZ126 is available in Green SOT-23-5 and SC70-5 packages. It operates over an ambient temperature range of -40°C to +85°C.

LOGIC SYMBOL

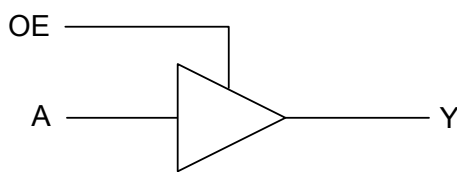

FEATURES

- **Ultra-High Speed:** $t_{PD} = 3.4ns$ (TYP) into 50pF at $V_{CC} = 3.3V$
- **High Output Drive:** $\pm 24mA$ at $V_{CC} = 3V$
- **Broad V_{CC} Operating Range:** 1.65V to 5.5V
- **Matches Performance of LCX Operated at $V_{CC} = 3.3V$**
- **Power Down High-Impedance Inputs/Output**
- **Over-Voltage Tolerant Inputs Facilitate 5V to 3V Translation**
- **Available in Green SOT-23-5 and SC70-5 Packages**

FUNCTION TABLE

| INPUTS | | OUTPUT |
|--------|---|--------|
| OE | A | Y |
| H | L | L |
| H | H | H |
| L | X | Z |

H = HIGH Logic Level
L = LOW Logic Level
X = Don't Care
Z = HIGH Impedance State

Small Logic Buffer with Three-State Output

SGM7SZ126

PACKAGE/ORDERING INFORMATION

| MODEL | PIN-PACKAGE | SPECIFIED TEMPERATURE RANGE | ORDERING NUMBER | PACKAGE MARKING | PACKAGE OPTION |
|-----------|-------------|-----------------------------|------------------|-----------------|---------------------|
| SGM7SZ126 | SC70-5 | -40°C to +85°C | SGM7SZ126YC5G/TR | SG0XX | Tape and Reel, 3000 |
| | SOT-23-5 | -40°C to +85°C | SGM7SZ126YN5G/TR | SG1XX | Tape and Reel, 3000 |

NOTE: XX = Date Code.

MARKING INFORMATION

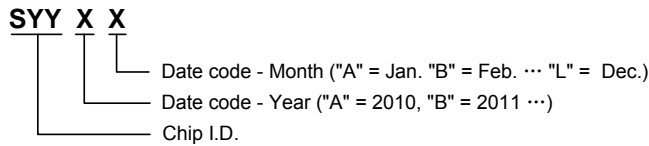

For example: SG0CC (2012, March)

ABSOLUTE MAXIMUM RATINGS

| | |
|---|-----------------|
| Supply Voltage, V_{CC} | -0.5V to 6.0V |
| DC Input Voltage, V_{IN} | -0.5V to 6.0V |
| DC Output Voltage, V_{OUT} | -0.5V to 6.0V |
| DC Input Diode Current, I_{IK} ($V_{IN} < -0.5V$)..... | -50mA |
| DC Output Diode Current, I_{OK} ($V_{OUT} < -0.5V$)..... | -50mA |
| DC Output Current, I_{OUT} | $\pm 50mA$ |
| DC V_{CC} or Ground Current, I_{CC} or I_{GND} | $\pm 50mA$ |
| Operating Temperature Range..... | -40°C to +85°C |
| Junction Temperature..... | 150°C |
| Storage Temperature Range..... | -65°C to +150°C |
| Lead Temperature (Soldering, 10sec)..... | 260°C |
| ESD Susceptibility | |
| HBM..... | 8000V |
| MM..... | 400V |

NOTE:

Stresses beyond those listed under "Absolute Maximum Ratings" may cause permanent damage to the device. These are stress ratings only, and functional operation of the device at these or any other conditions beyond those indicated in the operational sections of the specifications is not implied. Exposure to absolute maximum rating conditions for extended periods may affect device reliability.

CAUTION

This integrated circuit can be damaged by ESD if you don't pay attention to ESD protection. SGMICRO recommends that all integrated circuits be handled with appropriate precautions. Failure to observe proper handling and installation procedures can cause damage. ESD damage can range from subtle performance degradation to complete device failure. Precision integrated circuits may be more susceptible to damage because very small parametric changes could cause the device not to meet its published specifications.

SGMICRO reserves the right to make any change in circuit design, specification or other related things if necessary without notice at any time. Please contact SGMICRO sales office to get the latest datasheet.

PIN CONFIGURATIONS (TOP VIEW)

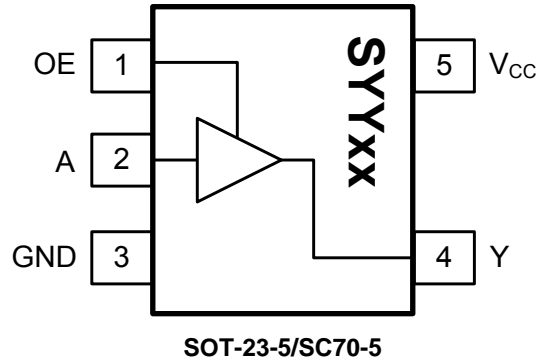

PIN DESCRIPTION

| PIN | NAME | FUNCTION |
|-----|-----------------|---|
| 1 | OE | Input. Unused input must be held high or low. It may not float. |
| 2 | A | Input. Unused input must be held high or low. It may not float. |
| 3 | GND | Ground. |
| 4 | Y | Output. |
| 5 | V _{CC} | Power Supply. |

ELECTRICAL CHARACTERISTICS(T_A = -40°C to +85°C, typical values are at T_A = +25°C, unless otherwise noted.)

| PARAMETER | SYMBOL | CONDITIONS | V _{CC} (V) | MIN | TYP | MAX | UNITS | |
|-------------------------------|---------------------------------|--|--------------------------|---------------------|------|---------------------|-------|----|
| GENERAL | | | | | | | | |
| Power Supply Range | V _{CC} | | | 1.65 | | 5.50 | V | |
| Supply Voltage Data Retention | | | | 1.50 | | 5.50 | V | |
| Input Voltage | V _{IN} | | | 0.00 | | 5.50 | V | |
| Output Voltage | V _{OUT} | Active State | | 0.00 | | V _{CC} | V | |
| | | Three-State | | 0.00 | | 5.50 | V | |
| Input Rise and Fall Times | t _r , t _f | | 1.8, 2.5 ± 0.2 | 0 | | 20 | ns/V | |
| | | | 3.3 ± 0.3 | 0 | | 10 | | |
| | | | 5.0 ± 0.5 | 0 | | 5 | | |
| DC PERFORMANCE | | | | | | | | |
| HIGH Level Input Voltage | V _{IH} | | 1.65 to 5.5 | 0.75V _{CC} | | | V | |
| LOW Level Input Voltage | V _{IL} | | 1.65 to 5.5 | | | 0.25V _{CC} | V | |
| HIGH Level Output Voltage | V _{OH} | V _{IN} = V _{IH} | I _{OH} = -100μA | 1.65 | 1.62 | 1.65 | V | |
| | | | | 1.80 | 1.77 | 1.80 | | |
| | | | | 2.30 | 2.27 | 2.30 | | |
| | | | | 3.00 | 2.97 | 3.00 | | |
| | | | 4.50 | 4.47 | 4.50 | | | |
| | | | I _{OH} = -4mA | 1.65 | 1.46 | 1.55 | | |
| | | | I _{OH} = -8mA | 2.30 | 2.03 | 2.18 | | |
| | | | I _{OH} = -16mA | 3.00 | 2.51 | 2.81 | | |
| LOW Level Output Voltage | V _{OL} | V _{IN} = V _{IL} | I _{OL} = 100μA | 1.65 | | 0.00 | 0.02 | V |
| | | | | 1.80 | | 0.00 | 0.02 | |
| | | | | 2.30 | | 0.00 | 0.02 | |
| | | | | 3.00 | | 0.00 | 0.02 | |
| | | | 4.50 | | 0.00 | 0.02 | | |
| | | | I _{OL} = 4mA | 1.65 | | 0.06 | 0.11 | |
| | | | I _{OL} = 8mA | 2.30 | | 0.09 | 0.17 | |
| | | | I _{OL} = 16mA | 3.00 | | 0.16 | 0.32 | |
| Input Leakage Current | I _{IN} | V _{IN} = 5.5V, GND | | 0 to 5.5 | | ±0.10 | ±5 | μA |
| | | | | | | | | |
| Power Off Leakage Current | I _{OFF} | V _{IN} or V _{OUT} = 5.5V | 0 | | 0.10 | 5 | μA | |
| Quiescent Supply Current | I _{CC} | V _{IN} = 5.5V, GND | 1.65 to 5.5 | | | 0.10 | 10 | μA |

ELECTRICAL CHARACTERISTICS(Typical values are at $T_A = +25^\circ\text{C}$, unless otherwise noted.)

| PARAMETER | SYMBOL | CONDITIONS | | MIN | TYP | MAX | UNITS |
|--|--------------------|--|---|--|------|-----|-------|
| AC PERFORMANCE | | | | | | | |
| Propagation Delay | t_{PHL}, t_{PLH} | $V_{CC} = 1.65\text{V}$ | $C_L = 15\text{pF}$, $R_D = 1\text{M}\Omega$, $S_1 = \text{OPEN}$, Figure 1, Figure 2 | | 8.9 | | ns |
| | | $V_{CC} = 1.80\text{V}$ | | | 7.1 | | |
| | | $V_{CC} = 2.50\text{V} \pm 0.20\text{V}$ | | | 3.9 | | |
| | | $V_{CC} = 3.30\text{V} \pm 0.30\text{V}$ | | | 3.0 | | |
| | | $V_{CC} = 5.00\text{V} \pm 0.50\text{V}$ | | | 2.3 | | |
| | | $V_{CC} = 3.30\text{V} \pm 0.30\text{V}$ | | $C_L = 50\text{pF}, R_D = 500\Omega$, $S_1 = \text{OPEN}$, Figure 1, Figure 2 | | 3.4 | |
| | | $V_{CC} = 5.00\text{V} \pm 0.50\text{V}$ | | 2.6 | | | |
| Output Enable Time | t_{PZL}, t_{PZH} | $V_{CC} = 1.65\text{V}$ | $C_L = 50\text{pF}, R_D = 500\Omega$, $R_U = 500\Omega$, $S_1 = \text{GND}$ for t_{PZH} , $S_1 = V_{IN}$ for t_{PZL} , $V_{IN} = 2V_{CC}$, Figure 1, Figure 2 | | 9.1 | | ns |
| | | $V_{CC} = 1.80\text{V}$ | | | 7.6 | | |
| | | $V_{CC} = 2.50\text{V} \pm 0.20\text{V}$ | | | 3.6 | | |
| | | $V_{CC} = 3.30\text{V} \pm 0.30\text{V}$ | | | 3.0 | | |
| | | $V_{CC} = 5.00\text{V} \pm 0.50\text{V}$ | | | 2.5 | | |
| Output Disable Time | t_{PLZ}, t_{PHZ} | $V_{CC} = 1.65\text{V}$ | $C_L = 50\text{pF}, R_D = 500\Omega$, $R_U = 500\Omega$, $S_1 = \text{GND}$ for t_{PHZ} , $S_1 = V_{IN}$ for t_{PLZ} , $V_{IN} = 2V_{CC}$, Figure 1, Figure 2 | | 8.2 | | ns |
| | | $V_{CC} = 1.80\text{V}$ | | | 7.1 | | |
| | | $V_{CC} = 2.50\text{V} \pm 0.20\text{V}$ | | | 5.0 | | |
| | | $V_{CC} = 3.30\text{V} \pm 0.30\text{V}$ | | | 4.2 | | |
| | | $V_{CC} = 5.00\text{V} \pm 0.50\text{V}$ | | | 3.5 | | |
| Input Capacitance | C_{IN} | $V_{CC} = 0\text{V}$ | | | 4.0 | | pF |
| Output Capacitance | C_{OUT} | $V_{CC} = 0\text{V}$ | | | 6.0 | | pF |
| Power Dissipation Capacitance ⁽²⁾ | C_{PD} | $V_{CC} = 3.30\text{V}$ | Figure 3 | | 15.0 | | pF |
| | | $V_{CC} = 5.00\text{V}$ | | | 17.0 | | |

NOTES:

- Unused inputs must be held HIGH or LOW. They may not float.
- C_{PD} is defined as the value of the internal equivalent capacitance which is derived from dynamic operating current consumption (I_{CCD}) at no output loading and operating at 50% duty cycle (see Figure 3). C_{PD} is related to dynamic operating current I_{CCD} by the expression: $I_{CCD} = (C_{PD})(V_{CC})(f_{IN}) + (I_{CC,Static})$.

TEST CIRCUITS

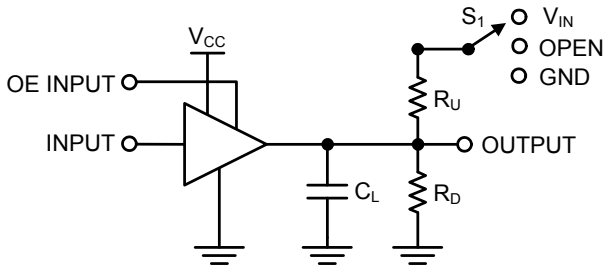

C_L includes load and stray capacitance;
Input PRR = 1.0MHz; t_w = 500ns.

Figure 1. AC Test Circuit

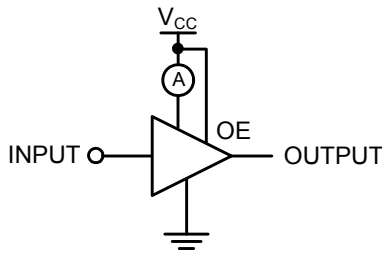

Input = AC Waveform; $t_r = t_f = 1.8$ ns;
PRR = 10MHz; Duty Cycle = 50%.

Figure 3. I_{CCD} Test Circuit

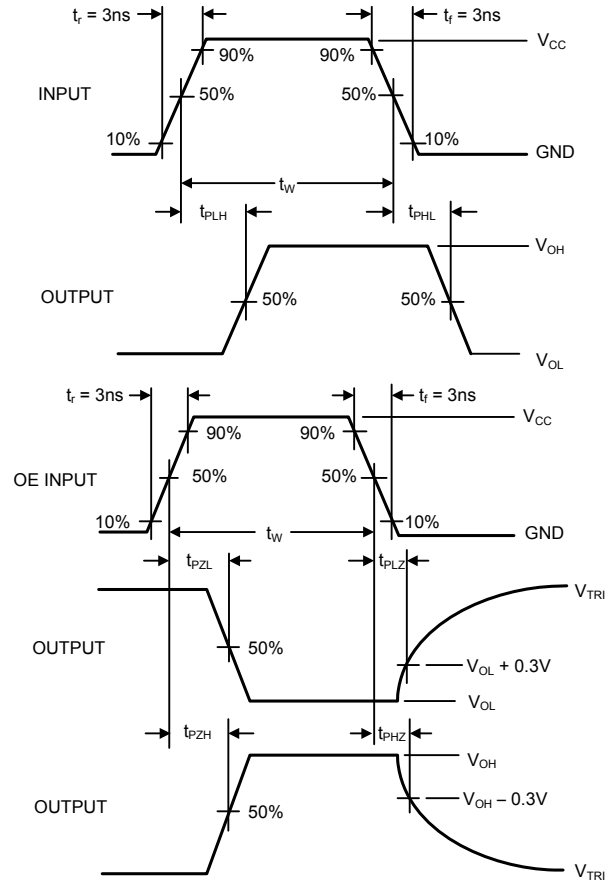
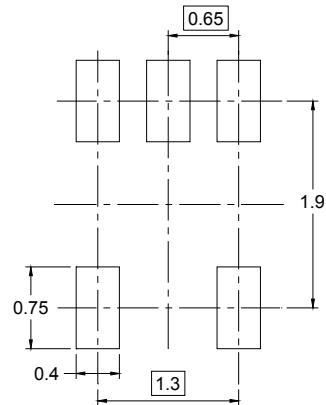
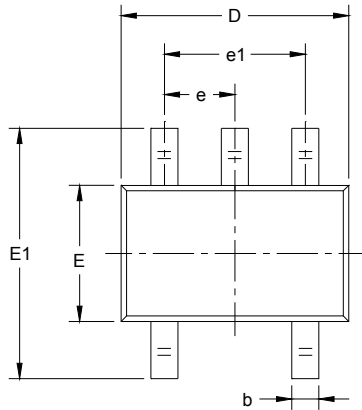

Figure 2. AC Waveforms

PACKAGE OUTLINE DIMENSIONS

SC70-5



RECOMMENDED LAND PATTERN (Unit: mm)

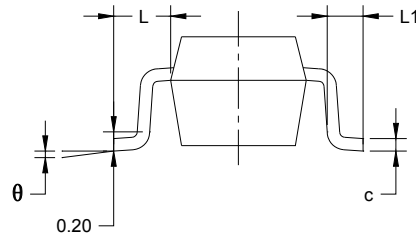
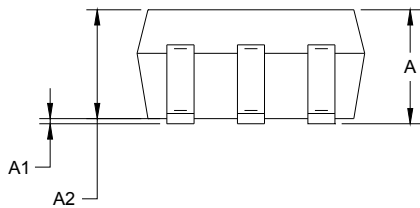

| Symbol | Dimensions In Millimeters | | Dimensions In Inches | |
|----------|------------------------------|-------|-------------------------|-------|
| | MIN | MAX | MIN | MAX |
| A | 0.900 | 1.100 | 0.035 | 0.043 |
| A1 | 0.000 | 0.100 | 0.000 | 0.004 |
| A2 | 0.900 | 1.000 | 0.035 | 0.039 |
| b | 0.150 | 0.350 | 0.006 | 0.014 |
| c | 0.080 | 0.150 | 0.003 | 0.006 |
| D | 2.000 | 2.200 | 0.079 | 0.087 |
| E | 1.150 | 1.350 | 0.045 | 0.053 |
| E1 | 2.150 | 2.450 | 0.085 | 0.096 |
| e | 0.65 TYP | | 0.026 TYP | |
| e1 | 1.300 BSC | | 0.051 BSC | |
| L | 0.525 REF | | 0.021 REF | |
| L1 | 0.260 | 0.460 | 0.010 | 0.018 |
| θ | 0° | 8° | 0° | 8° |

PACKAGE OUTLINE DIMENSIONS

SOT-23-5

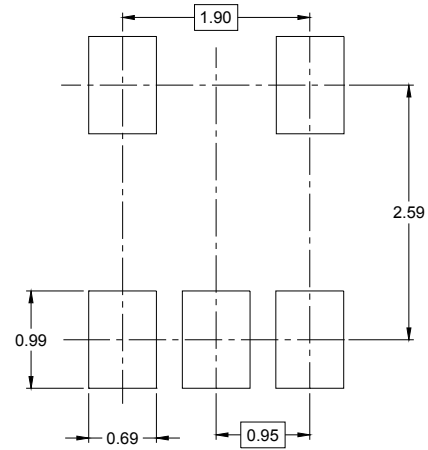
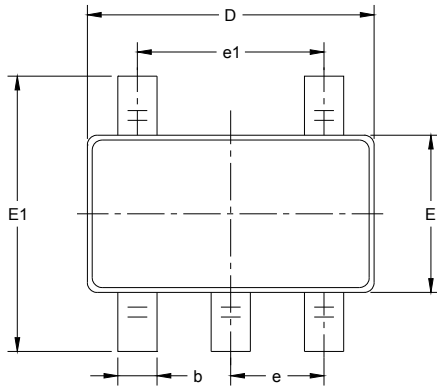

RECOMMENDED LAND PATTERN (Unit: mm)

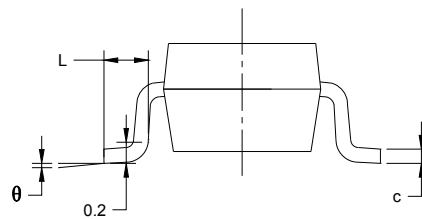
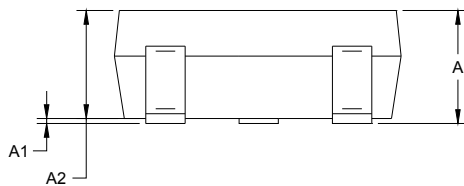

| Symbol | Dimensions In Millimeters | | Dimensions In Inches | |
|----------|------------------------------|-------|-------------------------|-------|
| | MIN | MAX | MIN | MAX |
| A | 1.050 | 1.250 | 0.041 | 0.049 |
| A1 | 0.000 | 0.100 | 0.000 | 0.004 |
| A2 | 1.050 | 1.150 | 0.041 | 0.045 |
| b | 0.300 | 0.500 | 0.012 | 0.020 |
| c | 0.100 | 0.200 | 0.004 | 0.008 |
| D | 2.820 | 3.020 | 0.111 | 0.119 |
| E | 1.500 | 1.700 | 0.059 | 0.067 |
| E1 | 2.650 | 2.950 | 0.104 | 0.116 |
| e | 0.950 BSC | | 0.037 BSC | |
| e1 | 1.900 BSC | | 0.075 BSC | |
| L | 0.300 | 0.600 | 0.012 | 0.024 |
| θ | 0° | 8° | 0° | 8° |

TAPE AND REEL INFORMATION

REEL DIMENSIONS

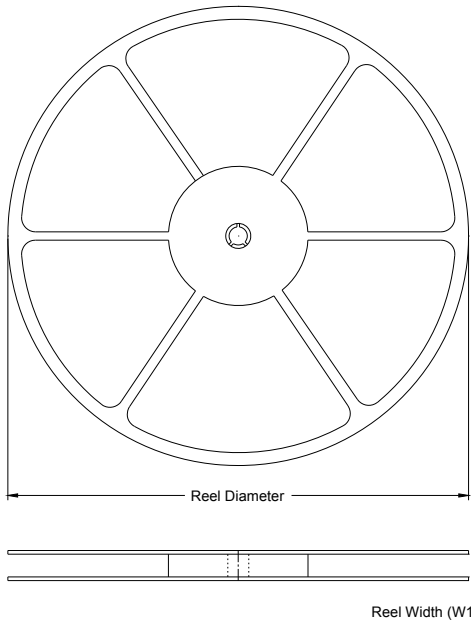

TAPE DIMENSIONS

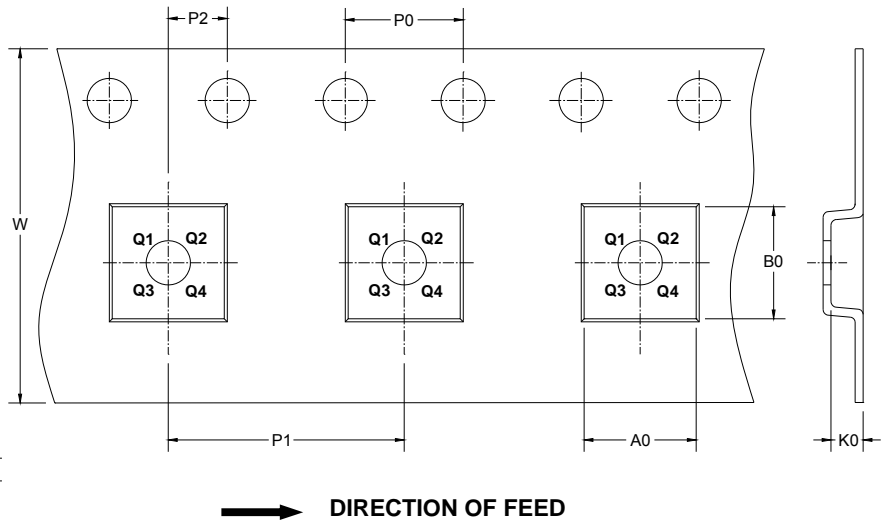

NOTE: The picture is only for reference. Please make the object as the standard.

KEY PARAMETER LIST OF TAPE AND REEL

| Package Type | Reel Diameter | Reel Width W1 (mm) | A0 (mm) | B0 (mm) | K0 (mm) | P0 (mm) | P1 (mm) | P2 (mm) | W (mm) | Pin1 Quadrant |
|--------------|---------------|--------------------|---------|---------|---------|---------|---------|---------|--------|---------------|
| SOT-23-5 | 7" | 9.5 | 3.2 | 3.2 | 1.4 | 4.0 | 4.0 | 2.0 | 8.0 | Q3 |
| SC70-5 | 7" | 9.5 | 2.25 | 2.55 | 1.20 | 4.0 | 4.0 | 2.0 | 8.0 | Q3 |

SGM7SZ126

Small Logic Buffer with Three-State Output

CARTON BOX DIMENSIONS

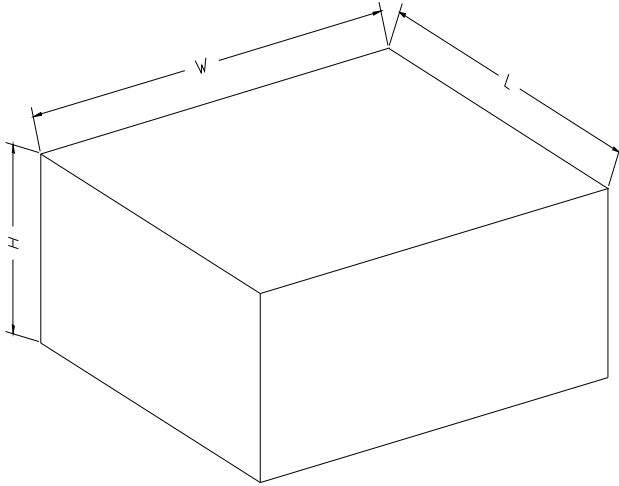

NOTE: The picture is only for reference. Please make the object as the standard.

KEY PARAMETER LIST OF CARTON BOX

| Reel Type | Length (mm) | Width (mm) | Height (mm) | Pizza/Carton |
|-------------|-------------|------------|-------------|--------------|
| 7" (Option) | 368 | 227 | 224 | 8 |
| 7" | 442 | 410 | 224 | 18 |